



GN ELECTRONICS

www.preferredinstruments.com



The 5002-01 Self – Check UV Scanner The Most Dependable & The Most Universal



The Quanta-Flame 5002 Scanners are equipped with an **Internal Microcomputer** and **External Indicator lights** for Flame status & Intensity and for the Output Signal status.



High flame signal sensitivity
Low electrical noise sensitivity
Operates with 120V (50/60Hz), 230V (50/60 Hz), and 24 V (AC or DC) (Depending on Model Ordered)
Self-Check mechanism rated for 100 Million Cycles

Available signal outputs(Depending on model ordered):
Supervised output flame relay contact
4 to 20mA (PLC or DCS Systems)
0 to 10V
Interface directly to burner control signal amplifier
Can be mounted in any position
NEMA 4 Construction
Dependable operation

Ultraviolet Model: 5002-01
Infrared Model: 5002-11
Dual UV/IR Model: 5002-21

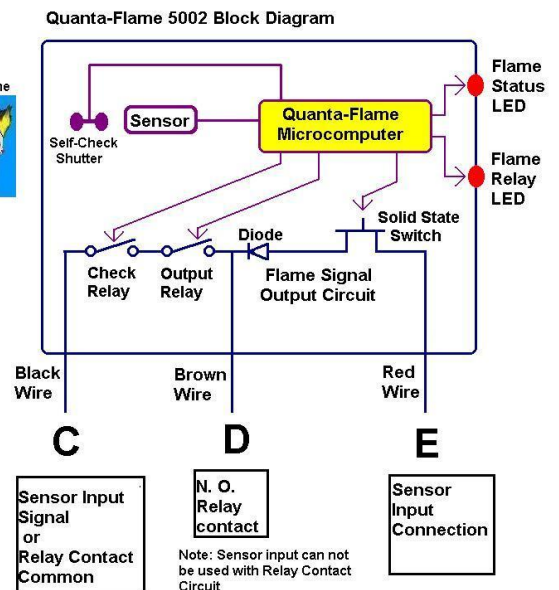

The 5002-01NC is the smaller non Self-Check version
Ultraviolet Model: 5002-01NC
Infrared Model: 5002-11NC
Ultraviolet & Infrared Model: 5002-21NC