

GN Electronics

A Division of Preferred Utilities Manufacturing Corporation



USER MANUAL for 5004-M-85 and 5004-M-85-R Quanta-Flame Primary Control

9958 North Alpine Road, Suite 104
Machesney Park, Illinois 6115
Phone: 203-743-6741
Fax: 203-798-7313
www.gnelectronics.com

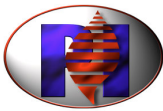
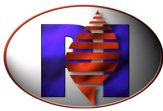

Table of Contents

A.	Description	3
B.	Quanta-Flame 5004-M-85 Specifications	8
C.	Installation	9
D.	Configuration	10
E.	Wiring	12
F.	Flame Sensors	16
G.	Test the Installation	22
H.	Modbus Communication	24
I.	Warranty and Returns	29

Note: All rights and privileges to the design of this product including the circuit layout and software are the exclusive property of GN Electronics, Inc. No part of which can be sold, used, or modified without the expressed written permission of GN Electronics Inc



A. DESCRIPTION

Quanta-Flame 5004-M-85

This is a microcomputer-controlled primary safety control burner management system. The diagnostic LCD display unit displays--- messages which supplies the operator with the status of the control.

The 5004-M-85 provides Standby, High Fire Purge, Low Fire Ignition, and Released to Modulate sequencing for oil and gas fuel burners.

The controller can be programmed by a dip switch that is located under the display. The dip switch is used for selecting the pre-purge timing, trial for ignition timing of the pilot, and Modbus ***select device address & counter, timer reset***. The plug-in connectors beside the controller allows wiring of the supply, fan, pilot & main valves, ignition transformer, valves, high purge, low purge, high fire proving interlock, low fire proving interlock, proof of valve closure, start limits, trip interlocks, 15 sec MTFI for oil, and remote reset. The flame sensor connector can accept flame rod, UV, UV self-checking, and IR sensors.

5004-M-85 Features

- ***Local*** LCD Display for Status and Troubleshooting
- ***Optional Remote Display (5004-216RN)***
- Sequence Status Lights
- ***Jacks for direct flame strength measurement 0-5VDC***
- Low Panel Profile
- Plug-in Field Wiring Terminals
- Field Selectable Pre-Purge Time
- ***Field Selectable Check for Power Failure***
- Field Selectable Trial for Ignition Time
- ***Field Selectable 10/15sec Interrupted Pilot***
- ***Field Selectable Check for Trip Interlock Short***
- Early Spark Termination
- Pilot Test Mode
- Burner Modulation Actuator Sequencing
- RS 485 Modbus Communication
- Single, or Dual, Flame Sensors
- Every unit interfaces to infra-red, ultraviolet, ultraviolet self-check or flame rod sensors. Sensor specific plug-in amplifiers are not required.
- ***Remote/Local Reset from Lockout State***
- ***Optional 16 Point Annunciator (QA16)***

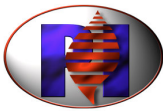

A. DESCRIPTION cont'd:

LED indicators:

Start Limits (green)- Indicates the presence of all the switches necessary to Start the burner sequence. If any of these switches open, the burner will shutdown without causing a Lockout.

Fan On (yellow)- Indicates the 5004 has commanded the combustion fan to run.

Pilot (yellow)- Indicates that the pilot valve is energized

Main (yellow)- Indicates that the main fuel valve is energized

Flame Fail (red)- Indicates that a Lockout occurred due to the Flame Sensor: Flame not detected during Pilot Trial, Main Flame Trial, or Auto.

False flame detected during Standby or Purge will cause this led to flash.

Safety Interlock (red)- Indicates that a Lockout has occurred due to: Trip Interlocks, Proof of Valve Closure, High or Low Fire proving switch, or internal error.

Trip Interlock Short will cause this led to flash (when S1-7 is ON)

Alarm (red)- Indicates a Lockout condition has occurred

Power (red)- Indicates that power is applied to the unit

Flame (red)- Indicates the presence of a flame signal at the control. *Led intensity indicates a relative flame strength.*

Low Fire (green)- Indicates that the 5004 has commanded the burner to move to Low fire

High Fire (red)- Indicates that the 5004 has commanded the burner to move to High fire

Automatic (yellow)- Indicates that the 5004 has released the burner to Automatic modulation

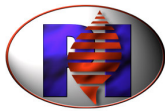

A. DESCRIPTION cont'd:

Function Descriptions:

False Flame Detection - The 5004 will Lockout if flame is detected *for over 2 seconds* during Standby or Purge.

Safe Start Check – During every burner startup sequence, the 5004 performs *hardware & software* self-tests to verify it's internal circuitry is functioning properly and also verifies that the Safety relay, Ignition relay, Pilot Relay, and the Main fuel valve relay are functioning properly.

If Check for Power Failure is selected and power was interrupted during a firing cycle, upon power up the control will lockout.

If Check for Trip Interlock Short is selected, before beginning Purge, if the Trip Interlock input is made when the Start input is made, the control will wait for up to 60 seconds for Trip Interlock to be released.

Proof of Valve Closure (POVC)- The 5004 will Lockout if the Main Valves are not proved closed during Standby, Purge and Pilot Trial for Ignition (PTFI). The 5004 will also Lockout if the Main Valves close when the burner is firing.

Proven High Fire / Purge- Proves that the high fire position and Purge air flow interlocks are made before Purge can begin, and requires these interlocks to be made throughout the Purge period. If these interlocks *open* during the Purge period for more than 30 seconds (cumulative), the 5004 will Lockout. *If interlocks are not made, at least once, throughout the Purge period the control will lockout after 5 minutes.* This insures a proper Purge. If

Proven Low Fire / Ignition- Proves the low fire position prior to ignition and light off of the burner. *If LF switch is not made within 5 minutes the control will lockout.*

Selectable Pilot Trial for Ignition (PTFI) Time- DIP switches allow selection of a 3, 5, or 10 second timing. See the Configuration section.

Early Spark Termination / Pilot Verification - The Ignition transformer spark is de-energized at the end of PTFI while the pilot valve continues to be energized for 5 seconds before the main valve is energized. This insures the sensor is not recognizing spark as a flame and that the pilot flame is stable, without a spark, before lighting the main burner.

Selectable Main Trial for Ignition (MTFI) Time- The default MTFI time is 10 seconds. Some #6 oil burners may require a 15 second MTFI to allow extra time for the cold oil to flow to the burner. Energizing terminal 27 changes the MTFI time from 10 seconds to 15 seconds. See the Wiring section.

Post Purge- After a burner shutdown (normal or Lockout), the Fan will continue to be energized for 15 seconds to Purge the furnace with fresh air. *A false flame will not cause a lockout for 45 seconds after a Post Purge started.*

Pilot Test Mode – In this mode, after the completion of PTFI, the Ignition transformer is de-energized, the Pilot valve remains energized, and the 5004 will not attempt to open the Main Valve. If the Flame sensor stops detecting a flame the 5004 will Lockout. This mode permits the technician to examine and adjust the pilot flame. The Pilot Test Mode is activated as follows:

- 1) Power down the 5004. The Start Limits must be made before powering-up the 5004.
- 2) Pressing and holding the RESET button, power-up the 5004.
- 3) Wait until *****Test Mode***** is displayed (approx. 10 sec), and then release RESET.



- 4) If the START LIMITS light is blinking , the 5004 is in Pilot Test Hold mode.
If not, the Start Limits input was not made when the 5004 was powered-up, and the 5004 is NOT in Pilot Test Hold mode, and will open the Main Valve.
- 5) “Pilot On-Test” is displayed when the pilot is open and Pilot Test Mode is active.
- 6) After the Pilot Test is done, open the Start Limits in order to exit Pilot Test Mode.

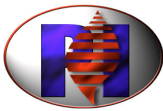

A. DESCRIPTION cont'd:

Function Descriptions cont'd:

Modulation Sequencing – This feature, via terminals 9 – 12, sequences the burner modulation actuator to Standby, High Fire / Purge, and Low Fire / Ignition positions. The Modulation contacts sequence as follows:

Control Status	Contacts Status
Control is not powered	AUTO to COM
Control is powered, limits are open	L FIRE to COM
High Fire Purge	H. FIRE to COM
Low Fire Start	L FIRE to COM
Control Releases to Automatic Modulation	AUTO to COM
Post Purge	L FIRE to COM
Lockout	L FIRE to COM

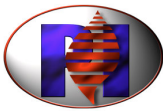

B. Quanta-Flame 5004-M-85 Specifications

Mechanical: 7.00L" by 5.00" W by 2.00" D

Weight: 2 Lbs

Operating Temperature: -40°F to +140°F (-40°C to +60°C) , UV scanners -20C to 60C

Electrical: Voltage: 120 VAC **+10% - 15%**, 50/60Hz
 Power consumption: 2VA

Flame Failure Response Time: 2.5 to 3.5 seconds

Purge Time: 30, 60, 90, 150, 180, 300, 450, or 900 seconds (DIP Switch selectable)

Pilot Trial for Ignition Time: 3, 5, or 10 seconds (DIP Switch selectable)

Flame Sensor Inputs (2): Ultraviolet and Flame Rod

Compatible Flame Sensors:	Flame Rod	
	Model 5004-01	Ultraviolet, non self-checking
	Model 5002-01NC	Ultraviolet, non self-checking
	Model 5002-01	Ultraviolet, self-checking
	Model 5002-11NC	Infrared

Output Terminal Load Ratings:

Total connected 120 VAC Load must not exceed 15 amps.

Terminals 9 – 12	Modulation Sequencing:	2 amps resistive
Terminals 18 – 19	Fan:	10 amps resistive: ½ HP inductive
Terminal 21	Ignition Transformer:	10 amps resistive, ¼ HP inductive
Terminal 22	Pilot Valve:	10 amps resistive, ¼ HP inductive
Terminal 23	Main Fuel Valve:	10 amps resistive, ¼ HP inductive
Terminal 29 – 30	Alarm Relay:	2 amps resistive

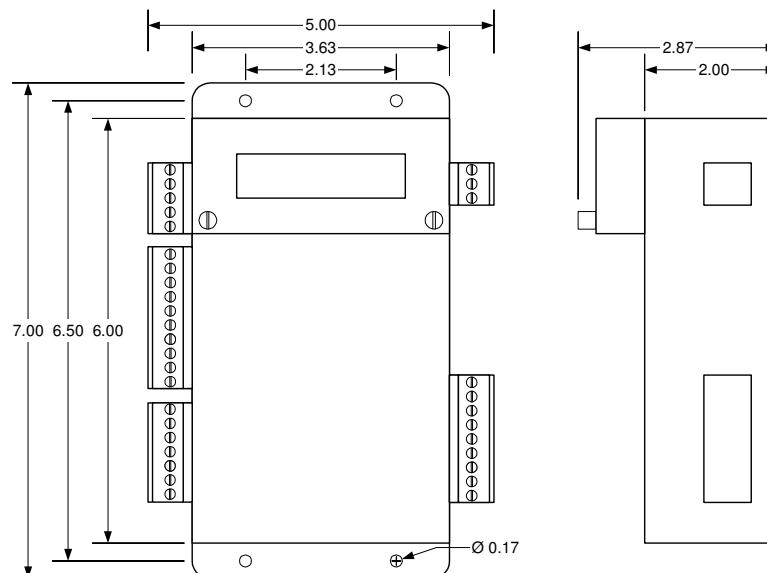



C. Installation

WARNING

Only qualified technicians with specific knowledge of the design of the burner and all applicable burner/boiler safety codes should configure and install the 5004-M-85. Incorrect installation can result in equipment damage, injury, or death.

- All system wiring should be run in accordance with the National Electrical Code and all local code requirements.
- Always remove all power to the system before wiring.
- Do not subject the controller to excessive vibration.
- Flame sensor wiring must be run in a separate conduit, with no other wiring. Use shielded cable, terminate shield as shown, and insulate all exposed shielding. Route Sensor wiring a sufficient distance away from any type of ignition or other wiring to avoid electrical noise interference. Each sensor wiring must be run separate from all other wires including other sensors. In some cases shielded cable or coax may be required for long distances or high electrical interference environments. Each pair of sensor leads should be in their own shielded or coaxial pair and terminated at the control.
- All wire near hot surfaces should be rated for 90°C (195°F) or at least 25°C (50°F) higher than the surface temperature.
- Keep the Ignition transformer (xfmr) high voltage wire away from the flame sensor wiring and all other 120 Vac wiring. Use only automotive style noise-suppression ignition wire. Mount the ignition transformer as close to the ignitor spark gap as practical. Ground the ignition transformer to metal that is connected to the ignitor, use star washers to cut through the paint.
- Keep VSD motor wiring away from the flame sensor wiring and all other 120 Vac wiring. Run motor wires in rigid metal conduit, or in EMT conduit with conducting compression fittings (Set screw hub fittings not allowed), or use shielded motor power cable. Run a Ground wire from the motor frame to the VSD frame in the same conduit as the motor wires. Also run a ground wire from the VSD frame to the power source ground.
- RS485 wiring should not be run in conduits with 120 Vac wiring.

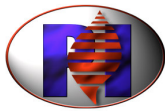

D. Configuration

WARNING

Only qualified technicians with specific knowledge of the design of the burner and all applicable burner/boiler safety codes should configure and install the 5004-M-85. Setting these switches incorrectly can result in equipment damage, injury, or death.

The DIP switches under the LCD display are used to configure the 5004-M-85.

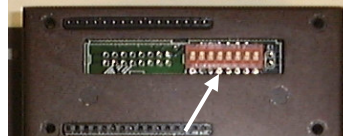

DIP Switch 1 set Lockout on Power Fail.

When DIP Switch 1 is ON and power to the control is interrupted during a normal cycle, Upon power up the display will indicate a Lockout-Power Fail

When DIP Switch 1 is OFF and power to the control is interrupted during a normal cycle, Upon power up the control will start a normal cycle if it was not in a Lockout state.

DIP Switches 2 through 4 set the Purge time.

The minimum Purge time is 30 seconds. DIP switches 2 is a 'x2' multiplier, DIP switches 3 is a 'x3' multiplier, DIP switches 4 is a 'x5' multiplier. ON = x1, OFF = x2, x3, x5. These switches can be used to vary the purge time as follows:

Switch 2	Switch 3	Switch 4	Purge Seconds	Explanation
ON	ON	ON	30	30 x 1 x 1 x 1
OFF	ON	ON	60	30 x 2 x 1 x 1
ON	OFF	ON	90	30 x 1 x 3 x 1
ON	ON	OFF	150	30 x 1 x 1 x 5
OFF	OFF	ON	180	30 x 2 x 3 x 1
OFF	ON	OFF	300	30 x 2 x 1 x 5
ON	OFF	OFF	450	30 x 1 x 3 x 5
OFF	OFF	OFF	900	30 x 2 x 3 x 5

DIP Switches 5 and 6 set the desired Pilot Trial for Ignition (PTFI) time.

Switch 5	Switch 6	Pilot Trial Seconds
OFF	OFF	3
ON	OFF	5
ON	ON	10

DIP Switch 7 set Hold-Trip Interlock is Short.

When DIP Switch 7 is ON and Trip Interlock Input is powered when Start Input is made, the control waits up to 60 seconds for Trip Interlock to be released. After 60 seconds the control will be locked.

When DIP Switch 7 is OFF, the control will continue into purge mode even when the Trip Interlock Input is made when Start Input is made.



DIP Switch 8 is used for configuring Modbus.

During normal operation: **DIP Switch 8 MUST be OFF.**

See Section I, “**Modbus Communication**”, for directions on how to use the DIP Switches to configure the Modbus Slave Address.

NOTE

After 4 hours of continuous operation, ALL current DIP Switch settings will be recorded in non-volatile memory. Subsequent DIP Switch changes will be ignored.



E. Wiring

Terminal Block Arrangement

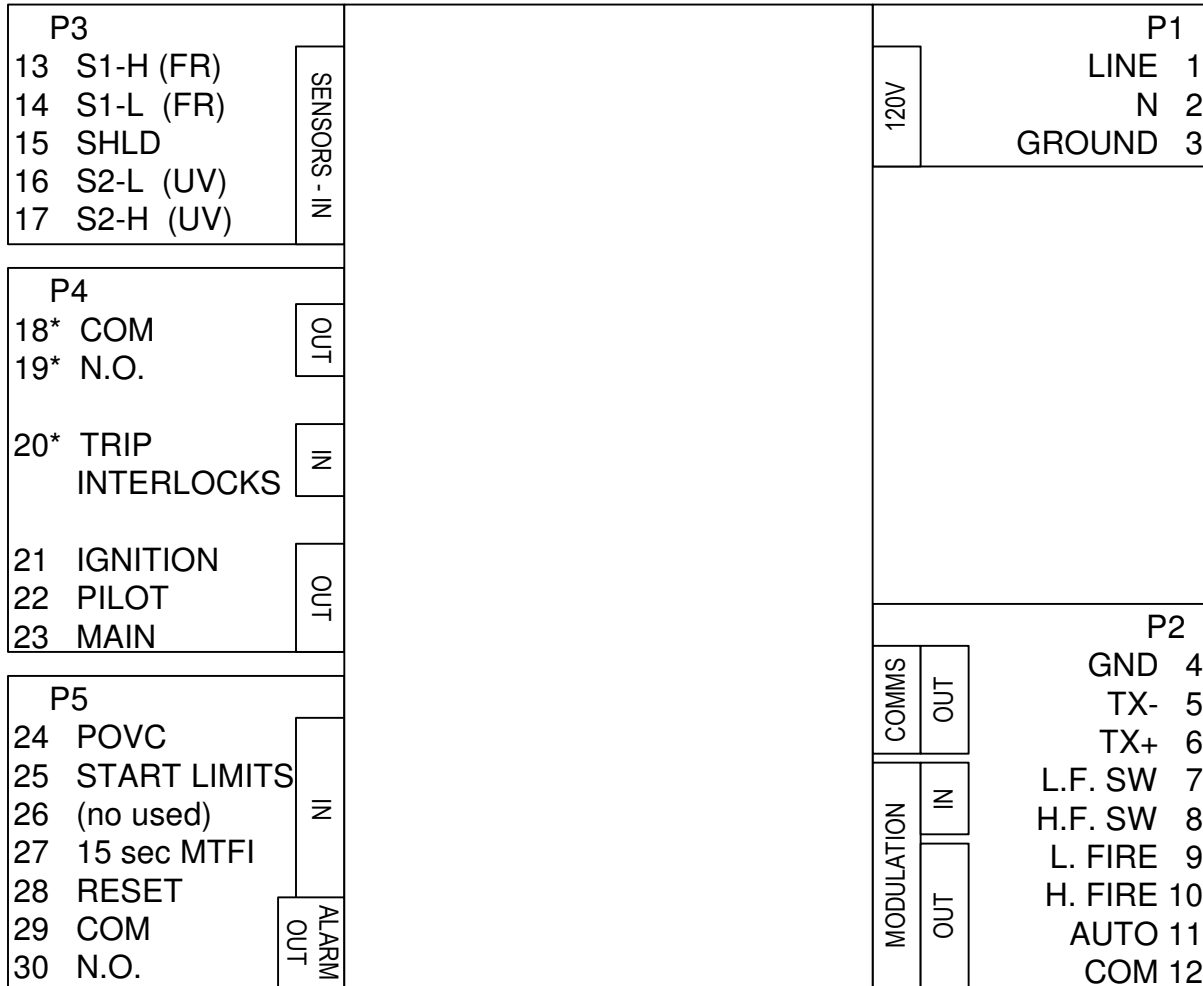

NOTE:

' * ' means that there is more than one terminal with the same number.
 All terminals with the same number are internally connected together.

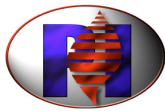

E. Wiring cont'd

Input Terminals

- 7 - Low fire switch input** - The low fire proving switch is connected as a permissive for pilot trial and for main flame trial. 120 Vac = Fuel control valve is at the Low Fire Start position.
- 8 - High fire switch input** - The high fire proving switch is connected as an interlock for Purge. The input must be made before Purge will start. 120 Vac = Purge positions and/or flow is proven.
- 13, 14 – Flame Rod Flame Sensor input, 'S1'** - See section F, 'Flame Sensors' for details. This input can also be connected to compatible 5002 series Ultraviolet or Infrared Flame Sensors. Dual Flame sensors can be installed and can be the same, or different, types of sensors. If either sensor detects flame, the 5004 considers the flame to be present.
- 16, 17 – Ultraviolet Flame Sensor input, 'S2'** - See section F, 'Flame Sensors' for details. This input can also be connected to compatible 5002 series Ultraviolet or Infrared Flame Sensors. Dual Flame sensors can be installed and can be the same, or different, types of sensors. If either sensor detects flame, the 5004 considers the flame to be present.
- 20 – Trip Interlocks** – Permissives required for Purge, Pilot Trial and burner Main valve firing. Trip Interlocks must be made no later than 10 seconds after the High Fire Switch Interlock is made during burner start-up and continuously thereafter. If any of these switches open, the burner will Lockout. 120 Vac = All Trip Interlocks are made.
- Terminal 20 is the 120 Vac power source for output terminals 21 – 22 (Ignition Xfmr, Pilot, and Main Valve). The current rating of the all Trip Interlock switches must exceed the loads on output terminals 21 – 22.
- 24 – POVC (Proof of Valve Closure)**- POVC switches on the main fuel valves for both fuels are wired in series to this terminal. Lockout occurs if the valves are not closed during Standby, Purge and PTFI . Lockout occurs if the valves are closed when the Main valve output is energized. 120 Vac = All main fuel valves are closed.
- 25 – Start Limits** – Permissive required to start, and continue operation of, the burner. If any of these switches open, the burner will shutdown without causing a Lockout. 120 Vac = All Start Limits are made.
- 27 – 15 sec MTFI (Main Trial For Ignition)** – The 5004-M default is a 10 second MTFI. Applying 120 Vac to this input changes the 5004-M MTFI to 15 seconds. Some heavy oil burners require a 15 sec MTFI. This input can be connected to an external Gas/Oil selector switch.
- 28 – Remote Reset**- An external **120VAC wired into a momentary N.O. pushbutton** will reset the 5004-M. This allows the user to Reset the 5004-M without opening a panel door. This input is optional, a Reset button is mounted on the face of the 5004-M. ***The control will reset only after it is gone into a lockout state.***

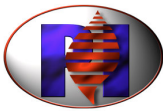

E. Wiring cont'd:

Output Terminals

- 21 – **Ignition**- Output to energize the ignition transformer.
- 22 – **Pilot**- Output to energize the burner pilot valve
- 23 – **Main**- Output to energize the burner main valve
- 18, 19 – **Fan**- A dry contact output which closes to start the combustion air fan or blower.
- 29, 30 – **Alarm**- A dry contact output which closes when the 5004-M is in Lockout. *Loosing and restoring power will not effect the state of the alarm relay.*
- 9, 10, 11, 12 – **Modulation** – Dry contacts which can be used to sequence the burner modulation actuator to High fire for Purge, to low fire for Ignition, and to release the burner for Automatic modulation. The 5004-M closes one set of contacts at a time, between Common and one of the three other terminals. The terminals for these contacts are:

- 9 - Low Fire
- 10 – High Fire
- 11 – Automatic
- 12 – Common

Burner Modulation Wiring

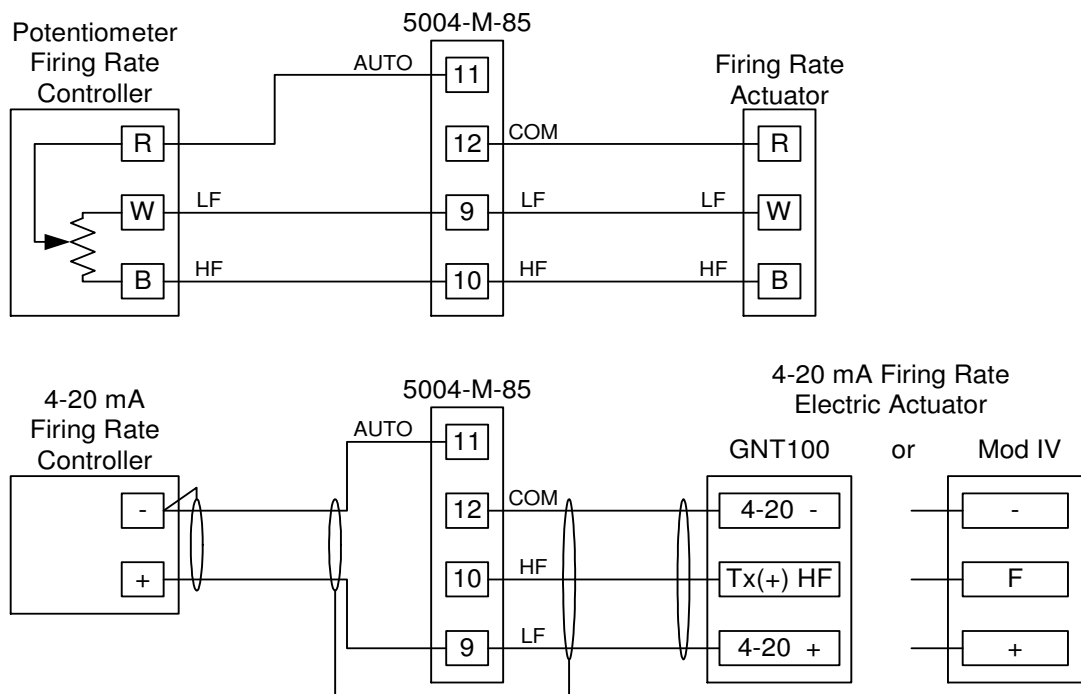

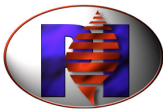

E. Wiring cont'd:

Typical 5004-M-85 System Wiring Diagram

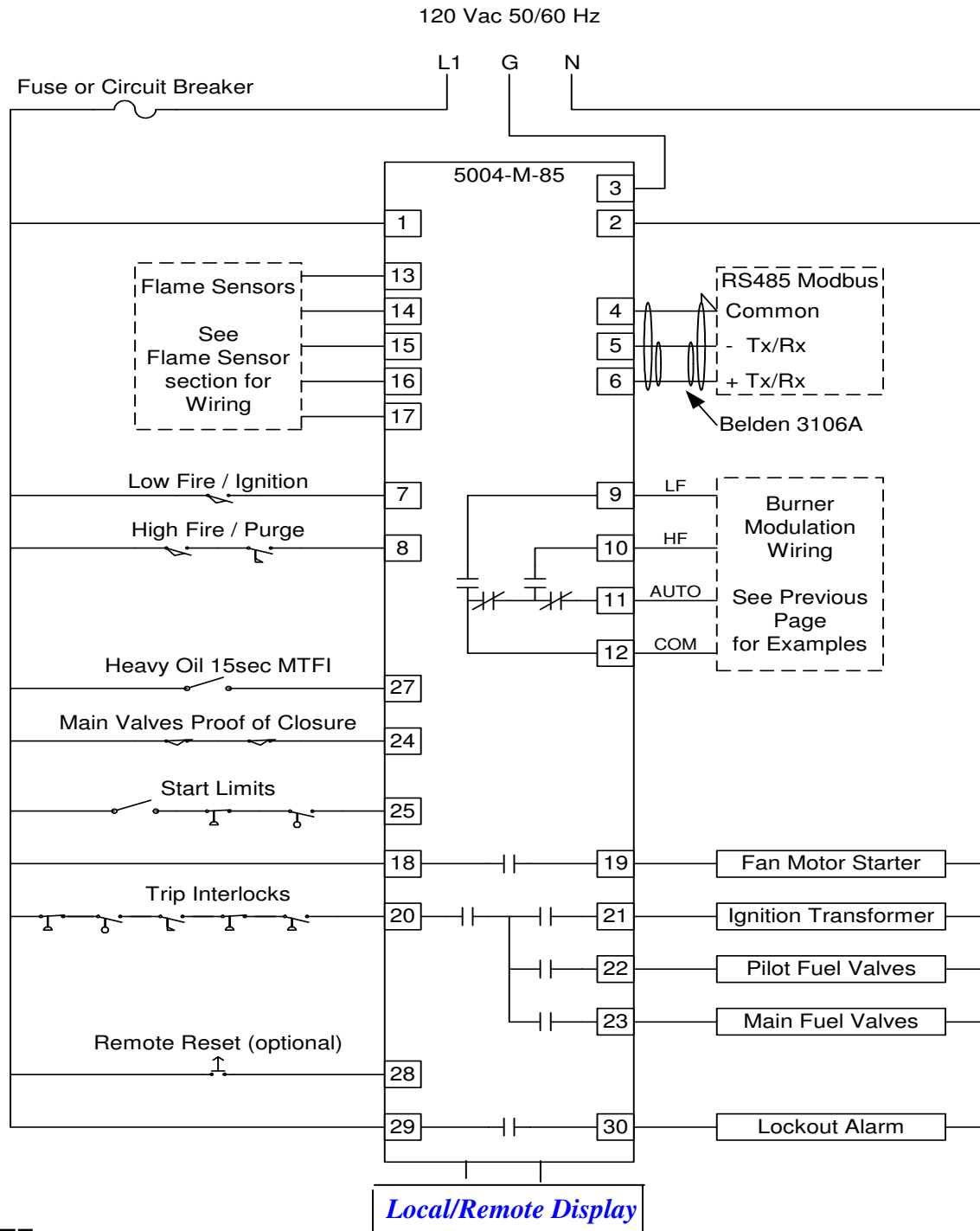

NOTE:

This is a 'typical' wiring diagram. The Required Limits, Interlocks, and other wiring varies based on the specific Burner design and Local Code Requirements.

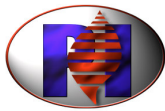

F. Flame Sensors:

Ultraviolet (Model 5004-01C) The UV sensor detects light emitted from the flame within the Ultraviolet light spectrum. Basic UV scanner with cable

Ultraviolet Self-Check (Model 5002-01) The UV Self-Check sensor detects light emitted from the flame within the Ultraviolet light spectrum. This sensor is intended for applications which continuously operate the burner (24 hours). The Self-check scanner interrupts the UV light from the burner every ten seconds to verify the proper operation of the sensing element and the internal components.

Ultraviolet Non Self-Check (Model 5002-01NC) The UV sensor detects light emitted from the flame within the Ultraviolet light spectrum. This sensor is intended for applications where a burner is cycles at least once within 24 hours.

Infra Red (Model 5002-11NC) The IR sensor detects light emitted from the flame within the Infra Red light spectrum. This sensor detects fluctuation of flame intensity.

Flame Rod The flame rod works on the principle of Flame rectification and senses a small direct current flowing through the flame between the flame rod and the burner ground.

Quanta-Flame 5004-012 Flame Scanners:

Catalog Number	Description
5004-01-0-0	5004-01 UV Scanner with <i>90 degree angle mount</i> , <u>no</u> cable included
5004-01-0-C	5004-01 UV Scanner with <i>90 degree angle mount</i> , 5 feet of cable included
5004-01-S-0	5004-01 UV Scanner with <i>straight mount</i> , <u>no</u> cable included
5004-01-S-C	5004-01 UV Scanner with <i>straight mount</i> , 5 feet of cable included
5004-00	5 feet of cable <u>with</u> connector

Quanta-Flame 5002 Self-Check Flame Scanners:

Ultraviolet Flame Detectors (cable not included)

Catalog Number	Description
Aluminum Alloy Body	
5002-01-120-0-00	UV or Flame Rod output; 120 VAC input; 1" NPT
Stainless Steel Body	
5002-01-120-0-SS	UV or Flame Rod output; 120 VAC input; 1" NPT

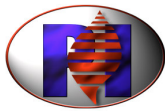

F. Flame Sensors cont'd:

Quanta-Flame 5002NC Non Self-Check Flame Scanners:

Ultraviolet Flame Detectors (cable not included)

Catalog Number	Description
Aluminum Alloy Body	
5002-01-NC-120-R-00-00	Contact closure output only: ½" NPT
5002-01-NC-120-F-00-00	UV/Flame Rod signal only; ½" NPT
5002-01-NC-120-R-00-HS	Contact closure output only. High Sensitivity; ½" NPT
5002-01-NC-120-F-00-HS	UV/Flame Rod signal only. High Sensitivity; ½" NPT
Stainless Steel Body	
5002-01-NC-120-R-SS-00	Contact closure output only: ½" NPT
5002-01-NC-120-F-SS-00	UV/Flame Rod signal only; ½" NPT
5002-01-NC-120-R-SS-HS	Contact closure output only. High Sensitivity; ½" NPT
5002-01-NC-120-F-SS-HS	UV/Flame Rod signal only. High Sensitivity; ½" NPT

Infrared Flame Detectors (cable not included)

Catalog Number	Description
Aluminum Alloy Body	
5002-11-NC-120-R-00-00	Contact closure output only: ½" NPT
5002-11-NC-120-F-00-00	UV/Flame Rod signal only; ½" NPT
5002-11-NC-120-R-00-HS	Contact closure output only. High Sensitivity; ½" NPT
5002-11-NC-120-F-00-HS	UV/Flame Rod signal only. High Sensitivity; ½" NPT
Stainless Steel Body	
5002-11-NC-120-R-SS-00	Contact closure output only: ½" NPT
5002-11-NC-120-F-SS-00	UV/Flame Rod signal only; ½" NPT
5002-11-NC-120-R-SS-HS	Contact closure output only. High Sensitivity; ½" NPT
5002-11-NC-120-F-SS-HS	UV/Flame Rod signal only. High Sensitivity; ½" NPT

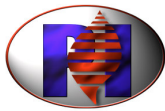

F. Flame Sensors cont'd:

Scanner Accessories:

Catalog Number	Description
5002-EP	Heavy Duty Scanner Housing
5002-EPSS	Heavy Duty Scanner Housing-Stainless Steel
5002-EPC	5000 & 5002 Scanner Series Terminal Connector
5000-02-05	Scanner Cable 5 feet – with connector
5000-02-10	Scanner Cable 10 feet – with connector
5000-02	Scanner Cable – Specify Length – connector not included. Price per foot
5002-02/91	Adapter for 5602-91-7 cable (from a 5602-91 scanner to the 5002-01)
-wt	Water tight connector added to Scanner Cable
5000-01UFL	5002 scanner line filter

Scanner Mounting Hardware:

Catalog Number	Description
5000-01-00L	Replacement quartz lens for mtg nipple 5000-01-00.
5000-73/74-SS	Swivel mount, 2" NPT x 1" NPTF, Stainless steel.
5000-475	Single piece nipple, 1" NPT x 4" long with quartz lens and purge connection.
5000-01-00-SS	Mounting nipple for 5000-001 scanner including quartz lens, 1" NPT x 4" long. Stainless steel.
5000-11-00-SS	Mounting nipple for 5000-001 scanner including glass lens, 1" NPT x 4" long. Stainless steel.
5000-01-00A	Stainless Steel mtg. nipple for 5000-001 scanner with insert quartz lens for higher pressure applications.
5000-01-04-CT	Mtg nipple for scanners with 1" threads, carbon Teflon for 450 deg. F service. 1" NPT x 4" long.

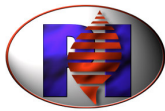

F. Flame Sensors cont'd:

Mounting Nipples & Lenses for 5004-01 Scanners:

The following parts are used in applications to reduce the heat transfer effects upon the flame scanner. In addition some of these components also have magnifying lenses to improve flame signal detection.

Catalog Number	Description
7077-17-FP-0-200	Insulator with <i>Flat</i> Quartz Lens; <u>no</u> Purge connection; 200°F Rating
7077-17-FP-P-200	Insulator with <i>Flat</i> Quartz Lens; <u>with</u> Purge connection; 200°F Rating
7077-17-FP-0-450	Insulator with <i>Flat</i> Quartz Lens; <u>no</u> Purge connection; 450°F Rating
7077-17-FP-P-450	Insulator with <i>Flat</i> Quartz Lens; <u>with</u> Purge connection; 450°F Rating
7077-17-MP-0-200	Insulator with <i>Magnifying</i> Quartz Lens; <u>no</u> Purge connection; 200°F Rating
7077-17-MP-P-200	Insulator with <i>Magnifying</i> Quartz Lens; <u>with</u> Purge connection; 200°F Rating
7077-17-MP-0-450	Insulator with <i>Magnifying</i> Quartz Lens; <u>no</u> Purge connection; 450°F Rating
7077-17-MP-P-450	Insulator with <i>Magnifying</i> Quartz Lens; <u>with</u> Purge connection; 450°F Rating

Additional scanner nipples without quartz lenses:

Catalog Number	Description
7077-17PN-200	Nipple, 1/2" NPT; <u>with</u> Purge connection; 200°F Rating
7077-17EN-200	Nipple, 1/2" NPT; <u>no</u> Purge connection; 200°F Rating
7077-17PN-450	Nipple, 1/2" NPT; <u>with</u> Purge connection; 450°F Rating
7077-17EN-450	Nipple, 1/2" NPT; <u>no</u> Purge connection; 450°F Rating

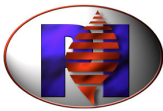

F. Flame Sensors cont'd:

Flame Sensor Wiring:

Flame Sensor

5004 - M - 85

Notes

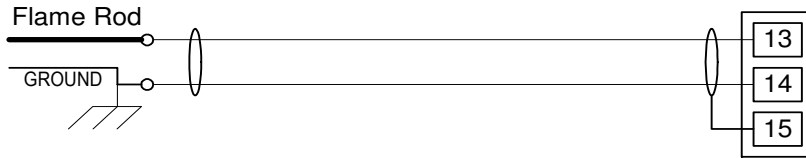

A Flame Rod Sensor can ONLY connect to terminals 13 -14

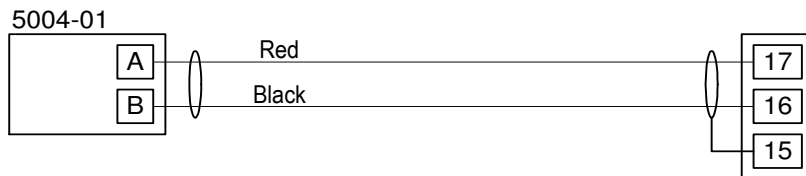

The 5004-01 Sensor can ONLY connect to terminals 16 -17

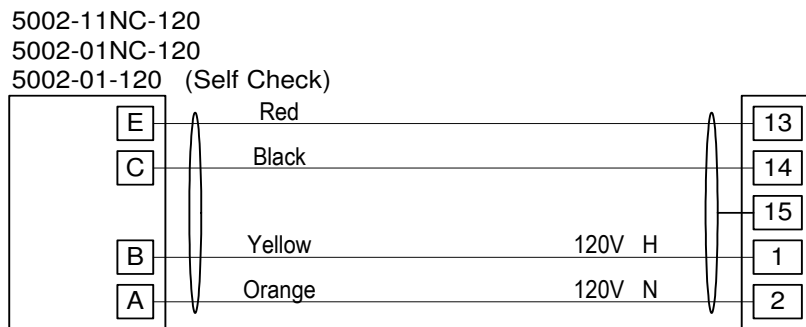

Any 5002-xx Scanner can connect to EITHER terminals 13 -14 OR terminals 16 -17

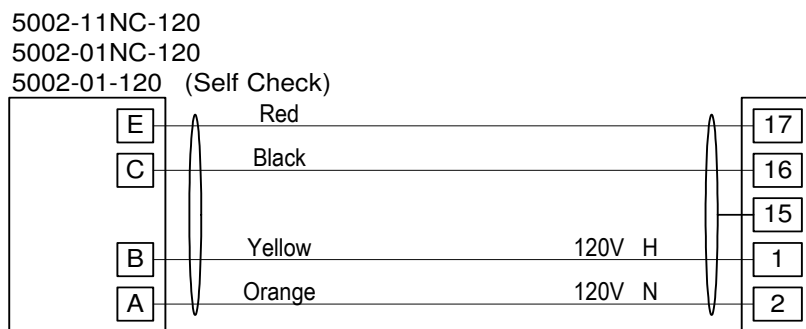

NOTE

Flame Sensor wiring must be run in a separate conduit, with no other wiring.

Keep Flame Sensor wiring as far away as possible from:
Ignition Xfmr high voltage wires and Variable Speed Drive motor wiring.

Use shielded cable. Connect Shield to terminal 15.
Insulate all exposed shields to prevent un-intended connections.



F. Flame Sensors cont'd:

Dual Flame Sensors

The 5004-M-85 has 2 Flame Sensor Inputs, and either 1 or 2 Flame Sensors may be installed. If either sensor detects flame, the 5004 considers the flame to be present. Dual flame sensor applications:

Preventing nuisance flame failure trips.

Dual fuel burners that have substantially different UV and IR outputs for each fuel.

Sighting different parts of the flame at low fire and high fire.

Example:

Dual Fuel Burner: Gas & Steam Atomized #6 Oil
Atomizing Steam blocks UV when firing Oil.
Oil flame has high IR signal.

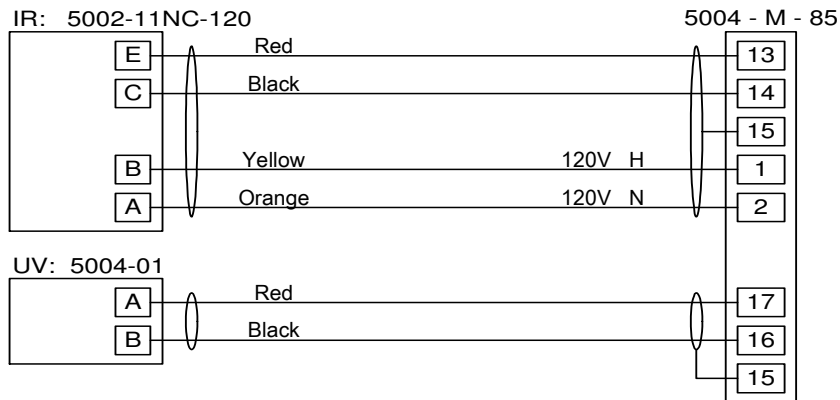

Manufacturing Process that can not tolerate nuisance trips.

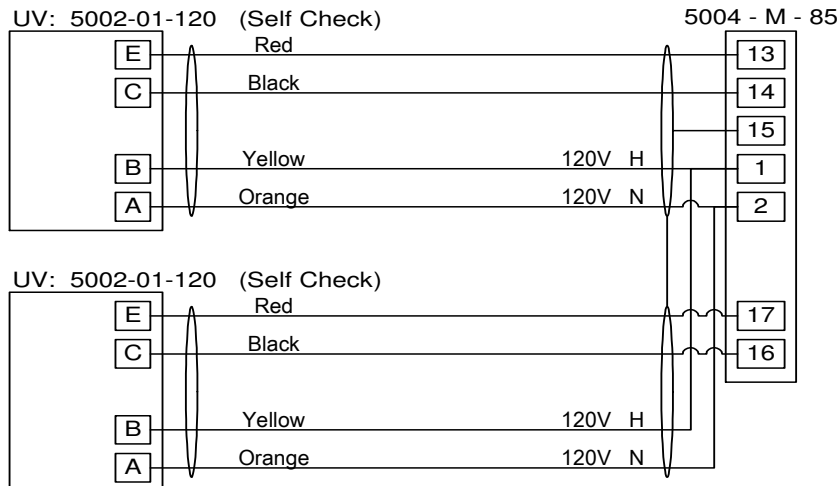

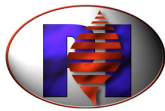

G. Test the Installation:

These tests must be performed after installation to insure that the 5004-M-85 and the connected sensor are operating properly; **these procedures are mandatory.**

These tests must be performed after installation of a 5004 control. This includes both new installations and those cases when one is replacing an existing control.

Insert the positive probe of a 0-10 VDC digital voltmeter into the test point on the front cover of the 5004; insert the negative probe to ground point. Good flame signal strength will read between 2 and 5 VDC; anything below 1 VDC is inadequate. The red FLAME light illuminates when a flame signal is indicated.

Spark Sighting Test

- 1) Manually shut off the fuel supply to the both the pilot and to the main burner.
- 2) Start the system in Pilot Test Mode (see page 5), while measuring the Flame signal.
- 3) If a flame signal is greater than 1 VDC for more than three seconds during the trial for ignition, then the sensor is picking up a signal from the spark plug. Find the problem and correct it before resuming normal operation.

Pilot Flame Failure Test

- 1) Manually shut off the fuel supply to both the pilot and to the main burner.
- 2) Start the system in Pilot Test Mode (see page 5).
- 3) The controller should lock out.
- 4) If the controller does not Lockout, then the controller is detecting a false flame signal. Find the problem and correct it before resuming normal operation.

Main Flame Failure Test

- 1) Manually shut off the fuel supply to the main burner but not to the pilot.
- 2) Start the system normally. This should ignite the pilot and then Lockout out after pilot turns off.
- 3) If the controller does not Lockout, then the controller is detecting a false flame signal. Find the problem and correct it before resuming normal operation.

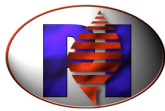

G. Test the Installation cont'd:

Minimum Pilot Test

Run the following test procedures to ensure that the sensor will not detect a pilot flame that is too small to reliably light the main flame:

- 1) Manually shut off the fuel supply to the burner, but not to the pilot.
- 2) Start the system in Pilot Test Mode (see page 5).
- 3) The control will hold the operating sequence after the pilot trial for ignition is done. Measure signal strength as described above.
- 4) Reduce the pilot fuel until the FLAME light turns off, then Increase pilot fuel until the flame signal is just above 1 VDC, and FLAME light is ON.
- 5) This is the minimum pilot. If you don't think this flame will safely light the main burner, re-align the sensor so that it requires a larger pilot flame and repeat steps 2 through 4.
- 6) **Open Start ILK** to exit Pilot Test Mode. The burner will shutdown and then begin the normal start-up sequence again. **Note: RESET switch functions only when the control is in Lockout Mode.**
- 7) During Purge, Open the manual fuel shutoff valve for the main burner.
- 8) If the main burner does not light within five seconds from the time the Main valve starts to open, immediately shut off the burner.
- 9) If the main burner failed to light, it requires a larger a larger pilot flame. Repeat steps 1 through 8 until the main burner lights off smoothly and reliably.

Note

Periodically check all interlock and limit switches by manually causing them to trip during burner operation to make sure they cause the burner to shut down.

Warning

Never operate a system that is improperly adjusted or has faulty interlocks or limit switches. Always replace faulty equipment with new equipment before resuming operation. Operating a system with defective safety equipment can cause explosions, injuries, and property damage.

Warning

If the system blows the 120 Vac power fuse due to field overloads (or shorts) in the Ignitor, Pilot, or Main Valve output circuits, there may be internal damage to the 5004-M-85 output relay contacts that could be a safety hazard. The 5004-M-85 should be removed from the burner and either be replaced, or be returned to GN Electronics for replacement of these relays. These relays are not field repairable.

Technician Test Tool

Catalog Number	Description
5004-04FS	Current meter and Source (4 to 20 mA) and Flame Simulator for Ultraviolet and Flame Rod Controls
5004-85-TESTER	Tester for testing proper functioning of the Inputs/Outputs w/ FR/UV simulation

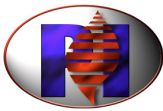

H. 5004-M-85 Modbus Communications

The operation of the 5004-M-85 can be monitored via the RS485 Modbus communications link. Modbus also provides access to the Historical data in the 5004-M-85: The last 6 Lockout reasons, burner Run hours, and burner Start cycles.

Modbus Specification:

Electrical:	2 Wire RS485 half-duplex, non-isolated
Protocol:	RTU
Baud Rate:	4800
Start Bits	1
Stop Bits	1
Data Bits	8
Parity	None
Modbus Point Type:	Holding Register (400xx series)
Modbus Functions supported:	Function 03: Read Multiple Holding Registers
Maximum Registers Requested/Poll	6

Modbus Wiring Terminals

- 4 - RS485 DC Common
- 5 - RS485 (-)
- 6 - RS485 (+)

The 5004-M-85 does not require an RS485 cable termination resistor, external or internal.

RS485 wiring should be kept separate from all 120 Vac wiring, the Ignition xfmr wiring, and any VSD wiring to prevent electrical noise interference.

Belden 3106A shielded cable, or equivalent RS485 rated cabling, should be used for noise rejection and reliable communications.

The Modbus Master device that is being used to Poll the 5004-M-85 should include an RS485 electrical interface with a 'Biasing' circuit to force the RS485 cable to a Logic 'High' in between transmissions.

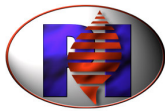

H. 5004-M-85 Modbus Communications cont'd:

Configuring the 5004-M-85 Modbus Device Address:

The 5004-M-85 is assigned a Device address as follows:

1. Power down the control.
2. Remove the LCD display, or cover plate, to expose the DIP switches. (see pg xxx)
3. Write down the ON / OFF positions of DIP switches 1 – 6.
These settings must be restored to the original settings at the end of this procedure.

WARNING: DIP switch positions 1 – 6 determine the Purge time and the Pilot Trial for Ignition time. Setting these switches to an incorrect value at the end of this procedure can result in equipment damage, injury, or death.

4. Set DIP switches 1,2,3,4,5,6 to the desired slave address (1-63).
Switches 1-6 are a Binary code, Switch 6 is the LSB, Switch 1 is the MSB, ON = '1'.
Examples: 000001 = 1, 000010 = 2, 000011 = 3, 000100 = 4,
5. Set DIP switches 7,8 =ON position.
6. Re-Install the LCD display on the control. Power up the control, while holding down the RESET switch for 25 seconds.
7. The LCD will display ** Test Mode ** for the first 20 seconds and then display the following message:.

SLAVE ADDRESS=XX
****RESET SW1****

xx – setting of the slave address

8. The slave address is recorded into EEPROM
9. Power down the controller.
10. Set DIP switch positions 1-6 to the settings written down in step 3 above.
Set DIP switch position 8 to OFF position.

WARNING: Setting these switches to an incorrect value can result in equipment damage, injury, or death.

11. Power up the controller and operate the burner normally.

NOTE

After 4 hours of continuous operation, ALL current DIP Switch settings will be recorded in non-volatile memory. Subsequent DIP Switch changes will be ignored.

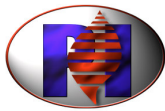

H. 5004-M-85 Modbus Communications cont'd:

Table of Modbus Registers provided by the 5004-M-85:

<u>Message Register</u>	<u>Value</u>
40001=State/Status	1= Standby 2=Waiting for interlock to make 3=Moving to purge 4=Purging 5=Moving to ignition 6=PTFI 7=MTFI 8=Released to modulate 9=Post purge 10=Lockout 11=Waiting for interlock to release
40002=State/Status Bits (Bit format)	Bit0=Standby Bit1=Waiting for interlock to make Bit2=Moving to purge Bit3=Purging Bit4=Moving to ignition Bit5=PTFI Bit6=MTFI Bit7=Released to modulate Bit8=Post purge Bit9=Lockout Bit10= Waiting for interlock to release
40003= Timer: Purge Minutes	0 – 15 minutes
40004= Timer: Purge, PTFI, MTFI, PostPurge seconds	0 – 59 seconds
40005= Timer Reason (Bit format)	Bit0=Purge Bit1=PTFI Bit2=MTFI Bit3=PostPurge
40006=Flame Sensor S1 Intensity	0-50 (0.0V to 5.0V)
40007=Flame Sensor S2 Intensity	0-50 (0.0V to 5.0V)

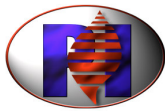

H. 5004-M-85 Modbus Communications cont'd:

Table of Modbus Registers provided by the 5004-M-85 cont'd:

<u>Message Register</u>	<u>Value</u>
40008=Current Lockout Reason	5=LFS Fail during MTFI 8=Relay Fail 9=Internal Fail 11=POVC Switch Short 16=Pilot Flame Fail (PTFI) 17=Main Flame Fail (MTFI) 20=Power Failure 21=Main Flame Fail 22=False Flame 25=Trip Interlocks Short 26=Rom Fail 27=Clock Fail 28=LFS Fail during PTFI 35=Proof Purge Fail 38=LFS Fail during Light Off 40=Trip Interlock Fail 41=POVC Fail 46=Opto Failed
40009=Current Hold Reason	0= Not Holding 1=Waiting for HF Switch 2=Waiting for LF Switch 3=Waiting for Trip Interlock
40010=State of each Input (Bit format)	Bit0=Trip Interlocks Bit1=Start Limits Bit2=POVC Bit3=Reset Bit4=LFS Bit5=Sensor Bit6=HFS Bit7=15 sec MTFI
40011=State of each Output (Bit format)	Bit0=Low Fire Bit1=Fan Bit2=Alarm Bit3=Auto Bit4=Ignition Bit5=Pilot Bit6=Main Bit7=High Fire

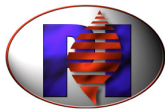

H. 5004-M-85 Modbus Communications cont'd:

Table of Modbus Registers provided by the 5004-M-85 cont'd:

Message Register	Value
Historical Lockout Data	
40012	1'st Lockout Code (oldest)
40013	2'nd Lockout Code
40014	3'rd Lockout Code
40015	4'th Lockout Code
40016	5'th Lockout Code
40017	6'th Lockout Code (newest)

See 40008 for the Lockout code definitions

40018= Run Time	0-65535 Hours
40019= Run Time	0-59 Minutes
40020= Start Cycles	0-65535 Cycles



I. Warranty and Returns

The 5004-M-85 is warranted for one (1) year from the date of delivery against manufacturing defects only. GN Electronics standards terms and conditions apply.

GN Electronics' liability for its products, whether due to breach of warranty, negligence, strict liability, or otherwise, is limited to the furnishing of replacement parts and GN Electronics will not be liable for any other injury, loss, damage or expenses, whether direct or consequential, including but not limited to loss of use, income of, or damage to material arising in connection with the sale, installation, use of, inability to use or the repair or replacement of GN Electronics' products.

Defective units should be returned to G N Electronics. Controls should be well packed in a suitable container encased in appropriate stuffing.

**These Controls are factory assembled and are not internally serviceable.
The main cover is not to be removed for any reason. To do so voids all
warranties and liabilities from GN Electronics.**

All products should **be shipped prepaid to:**

**G N Electronics
Div of Preferred Utilities Manufacturing
31-35 South Street
Danbury, CT 06810**



Preferred Utilities Manufacturing Corp.
GN Electronics Flame Safeguard Products
Phone (203) 743-6741, Fax (203) 798-7313
www.preferredinstruments.com

Notes